

# KBAS121800 12V 180Ah



The Kaise Solar range is mainly used in the renewable energies industry, given their optimal performance in cyclic use. With lower acid density, excess of electrolyte and larger distance between plates the batteries maintain a low temperature and also slows down the plate grid corrosion speed. These batteries have a unique plate grid configuration which, alongside the high quality AGM separator and the battery management system, ensures the batteries have a longer service life. The valves were specially designed to control water loss and prevent air and other elements from getting in.



## Performance Characteristics

Nominal Voltage	12V	
Dimensions	Length (mm / inch)	483 / 19.0
	Width (mm / inch)	170 / 6.69
	Height (mm / inch)	238.5 / 9.39
	Total Height (mm / inch)	238.5 / 9.39
Approx. Weight	(Kg / lbs) 43.2 / 95.3	
Design Life	8 - 12 years	
Terminal	M8	
Container Material	ABS	
Rated Capacity	180.0 Ah / 1.80 A	(100hr, 1.80V/cell, 25°C / 77°F)
	156.0 Ah / 7.80 A	(20hr, 1.80V/cell, 25°C / 77°F)
	150.0 Ah / 15.0 A	(10hr, 1.80V/cell, 25°C / 77°F)
	129 Ah / 25.8 A	(5hr, 1.75V/cell, 25°C / 77°F)
	91.5 Ah / 91.5 A	(1hr, 1.60V/cell, 25°C / 77°F)
Max. Discharge Current	1500A (5s)	
Internal Resistance	Approx 3.5mΩ	
Operating Temp. Range	Discharge : -15 ~ 50°C (5 ~ 122°F)	
	Charge : 0 ~ 40°C (32 ~ 104°F)	
	Storage : -15 ~ 40°C (5 ~ 104°F)	
Nominal Operating Temp. Range	25 ± 3°C (77 ± 5°F)	
Cycle Use	Initial Charging Current less than 36A	
	Voltage: 14.4V ~ 15.0V at 25°C (77°F)	
	Temp. Coefficient: -30mV/°C	
Standby Use	Initial Charging Current less than 36A	
	Voltage: 13.5V ~ 13.8V at 25°C (77°F)	
	Temp. Coefficient: -20mV/°C	
Capacity affected by Temperature	40°C (104°F)	103%
	25°C (77°F)	100%
	0°C (32°F)	86%
Self Discharge	Fully charged Kaise Solar Series batteries may be stored for up to 6 months at 25°C (77°F) and then a freshening charge is required. For higher temperatures the time interval will be shorter.	

## Constant Current Discharge (Amperes) at 77°F (25°C)

Volts/cell	15min	30min	45min	1h	5h	10h	20h	100h
1.80V	207.4	134.6	100.4	79.2	25.2	15.0	7.80	1.80
1.75V	226.5	139.8	104.2	82.9	25.8	15.1	7.88	1.88
1.70V	241.8	145.5	108.4	85.5	26.5	15.3	8.03	2.03
1.65V	257.2	153.5	111.1	88.4	27.2	15.6	8.13	2.13
1.60V	275.0	162.0	115.8	91.5	28.1	15.8	8.18	2.18

## Dimensions and Terminal (Unit: mm (inches))

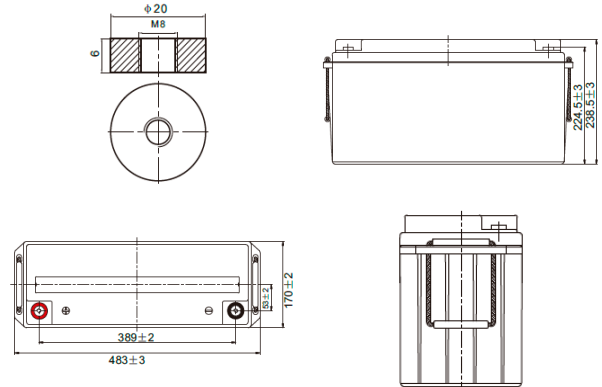

## Applications

- Renewable Energy
- Alarm systems
- Electric Test Equipment
- Emergency lighting systems
- Marine equipment
- Telecommunications systems

## Certifications

ISO 9001:2008 ISO 14001:2008



## Discharge Current vs. Discharge Voltage

Final discharge voltage V/CELL	1.8	1.75	1.7	1.6
Discharge current (A)	I ≤ 0.1CA	0.25CA ≥ I > 0.1CA	0.55CA ≥ I > 0.25CA	I > 0.55CA

## Constant Power Discharge (Watts per cell) at 77°F (25°C)

Volts/cell	15min	30min	45min	1h	5h	10h	20h
1.80V	381.8	252.7	191.6	152.0	49.1	29.6	15.4
1.75V	411.9	260.2	196.9	158.3	50.3	29.9	15.6
1.70V	433.6	269.3	204.0	162.7	51.4	30.2	15.8
1.65V	457.5	281.8	207.2	167.0	52.7	30.7	16.0
1.60V	481.2	295.4	214.8	172.0	54.2	31.0	16.1

(Note) The above characteristics data are average values obtained within three charge/discharge cycles not the minimum values.

## Charging Characteristic (float use)

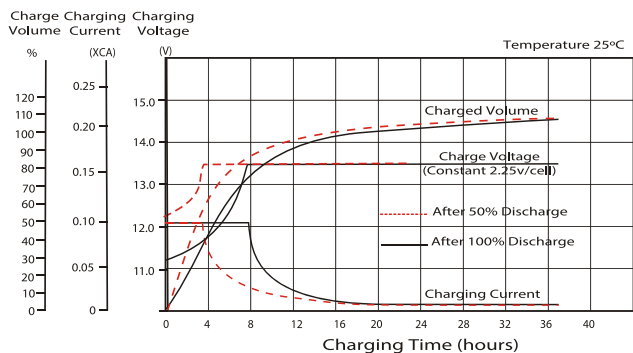

## Cycle Life in Relation to Depth of Discharge

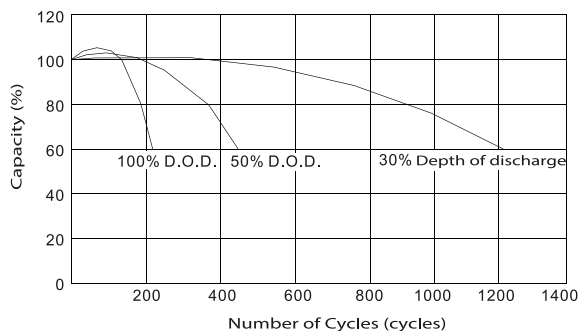

## Temperature Effects in Relation to Battery Capacity

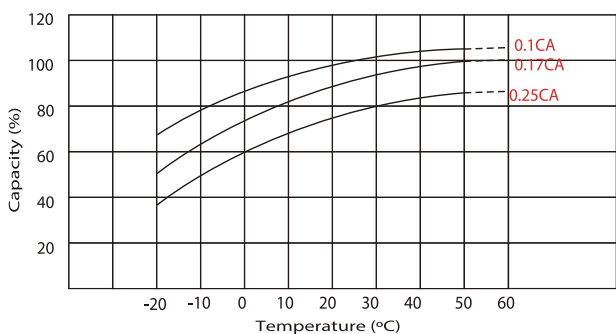

## Effect of Temperature on Long Terme Float Life

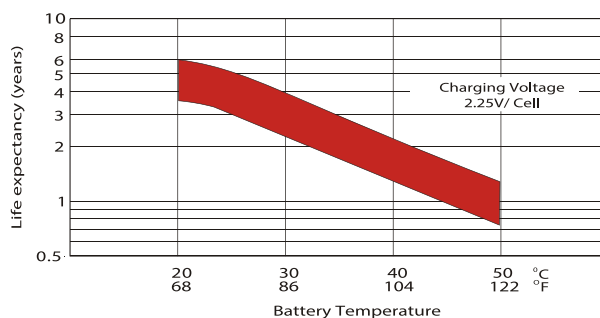

## Self Discharge Characteristics

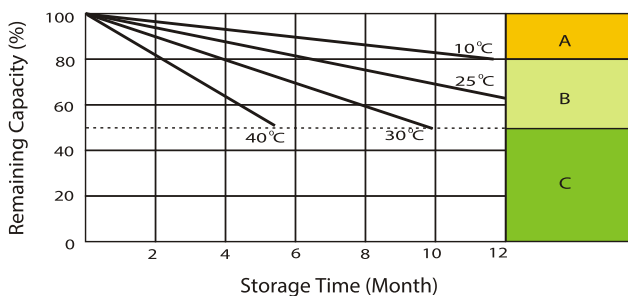

- A** With switch regulator (two-step controller) charge on curve max. charge voltage for max. 2 hrs/ day then switch over to continous charge.
- B** Standard charge without switching.
- C** Boost charge (Equalizing charge with external generator) charge on curve continous charge for max. 5 hrs/month, then switch over to curve Standard charge.

IMPORTANT NOTE: The specifications presented herein are subject to revision without notice.

