

# BATERÍA VME 12V 200 AH SEALED LEAD ACID MAINTENANCE FREE



## ● Características

Capacidad (25 °C)	10 HR ( 10.8 V )	200 Ah
	3 HR ( 10.8 V )	150 Ah
	1 HR ( 10.5 V )	110 Ah
Tipo de Terminal		T 16
Resistencia Interna Carga Completa ( 25 °C )		Aprox 3.5m Ω
Capacidad afectada por la temperatura ( 10 HR )	40 °C	102 %
	25 °C	100 %
	0 °C	85 %
	- 15 °C	65 %
Auto descarga ( 25 °C )	3 Meses	Capacidad Restante : 91%
	6 Meses	Capacidad Restante : 82%
	12 Meses	Capacidad Restante : 65%
Temperatura Nominal de Funcionamiento		25°C ± 3 °C ( 77 °F ± 5°F )
Rango de Temperatura de Funcionamiento	Descarga	-15 °C~50 °C ( 5 °F ~122 °F)
	Carga	-10 °C~50 °C ( 14°F ~122 °F)
	Almacenamiento	-20 °C ~50 °C (-4 °F~ 122 °F)
Tensión de Carga de Mantenimiento		13.50 to 13.80V Compensación de Temperatura : -18mV/°C
Voltaje de carga cíclico (25°C)		14.50 to 15.00V Compensación de Temperatura: -30mV/°C
Corriente de Carga Máxima		60 A
Corriente de Descarga Máxima		1400A ( 5 sec. )
Vida Flotante Diseñada		10 años



Batería **VME** AGM 12V-200 AH

## ● Especificaciones

Voltaje Nominal		12 V
Capacidad Nominal (índice de 10)		200Ah
Dimensiones	Largo	522 ±2mm
	Ancho	238 ± 2mm
	Altura	218 ± 2mm
	Altura Total	222 ±2mm
Peso Aproximado		59.5kg(131.2lbs)±3%

## ● Tipo de Terminal

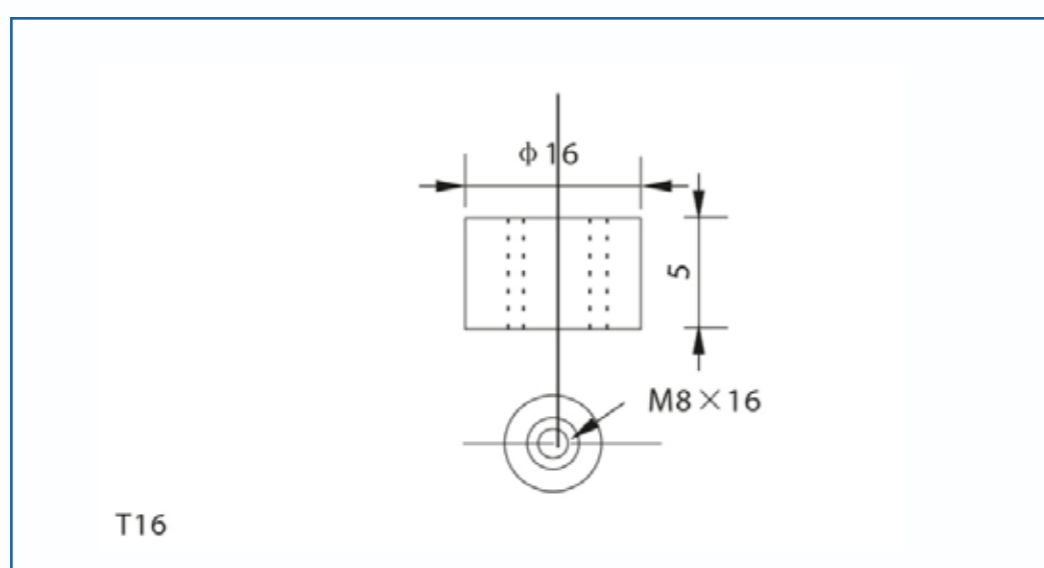

## ● Dimensiones Externas

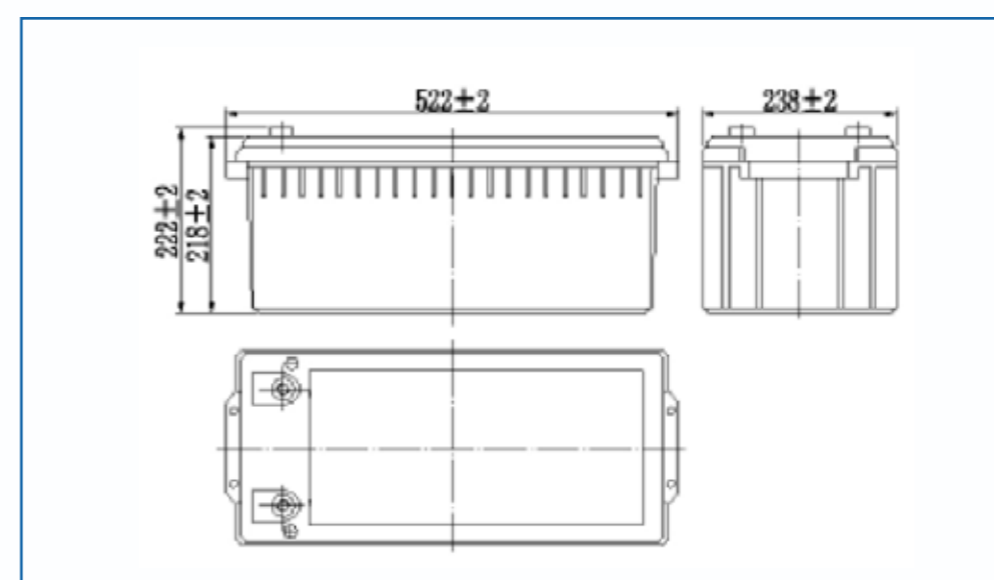

- Construcción

Componente	Placa Positiva	Placa Negativa	Contenedor	Cubierta	Separador	Electrolito	Válvula de Seguridad	Terminal
Materia Prima	Dióxido de Plomo	Plomo	ABS	ABS	AGM	Ácido Sulfúrico	Caucho	Cobre

- Características de descarga de corriente constante : A (25 ° C , 77 °F)

F.V / Time	10 min	15 min	30 min	60 min	2 h	3 h	4 h	5h	8 h	10 h	20 h
9.60 V	336	201	124	73.1	52.6	42.0	35.9	31.2	24.7	20.4	10.8
9.90 V	328	197	122	72.6	52.3	41.8	35.7	31.0	24.5	20.3	10.8
10.2 V	316	191	119	72.0	52.0	41.5	35.4	30.8	24.4	20.3	10.7
10.5 V	305	186	115	70.9	51.6	41.2	35.2	30.6	24.2	20.1	10.7
10.8 V	289	179	111	69.1	50.1	40.0	34.1	29.7	23.5	20.0	10.6

Características de descarga de potencia constante : W (25 °C, 77 °F)

F.V / Time	10 min	15 min	30 min	60 min	2h	3 h	4 h	5h	8 h	10 h	20 h
9.60 V	3689	2255	1409	846	619	494	424	369	293	243	129
9.90 V	3601	2210	1388	841	615	491	422	367	292	243	129
10.2 V	3468	2142	1353	834	611	488	419	364	290	242	129
10.5 V	3350	2091	1310	821	607	485	416	362	287	240	128
10.8 V	3173	2014	1268	800	589	470	404	351	279	239	127

\*Nota: Los datos de características anteriores pueden obtenerse dentro de tres ciclos de carga o descarga.